

FLO-TEK®

Flow better with us



CPVC Plumbing Solutions

FLOWGUARD™
PIPE & FITTINGS

Company Profile

Flo-Tek, the leading manufacturer and supplier of plastic Pipes, Tanks, Fittings and Irrigation products, since 1998.

Radical Investments (Pty) Ltd, trading as Flo-Tek Pipes & Irrigation was established in Botswana in 1998 manufacturing PVC pipes. In July 2003 and June 2004 Flo-Tek commenced manufacturing rotational moulded products and HDPE pipes, respectively.

The company was established in South Africa in 2005 and an HDPE pipe factory was started in Clayville in August 2007. Flo-Tek has fully fledged manufacturing facilities in Botswana, South Africa, Namibia & Angola, whereas we have distribution facilities in Zambia. Flo-Tek South Africa has since opened subsidiary companies in Dundee, Port Elizabeth, Nelspruit and Klerksdorp.

Within our Africa operations, we have trained staff who bring a wealth of knowledge and experience.

Flo-Tek ensures the best quality of products and the highest delivery standards.

www.flotekafrika.com

Flo-Tek's core business is the manufacturing and distribution of PVC-U and PVC-M Pressure Pipes & Fittings, HDPE Pipes & Fittings, Sewer Pipes & Fittings, Irrigation and Rotomoulded products. We also produce Borehole Casings, Screens and PVC Cable Ducts.

Our ISO 9001 certified factories in Botswana, South Africa and Angola enable us to manufacture our pipes and tanks as well as to distribute across the SADC region. Our factories have fully equipped laboratories which ensure Flo-Tek manufactures to SANS, BOBS & ISO specifications. Flo-Tek is also a member of SAPPMA.

Broad-Based Black Economic Empowerment (BBBEE)

Flo-Tek South Africa is a BEE compliant company. The principles of broad-based BEE, through stakeholder empowerment, have also been integrated into how we do business, and how we can assist and support our clients in how they do their business. The empowerment of women and the development of skills at lower levels of the organisations to facilitate career and personal growth opportunities are the particular areas that will continue to receive attention and focus within our business.

Sectors Serviced

- ◇ Civil & Infrastructure (Water & Sanitation)
- ◇ Mining & Industrial
- ◇ Irrigation
- ◇ Plumbing

Our Network

- Botswana
- South Africa
- Angola
- Namibia
- Zambia



Contents

Overview	5
Features and benefits	6
Installation.....	9
Product Data	14
CPVC compared to Copper	21
CPVC compared to PPR.....	22
Standard References.....	24
Frequently Asked Questions.....	25

Ideal for hot and cold water plumbing

Flo-Tek is a licensee of Lubrizol - USA,
manufacturing and marketing FlowGuard™
CPVC (Chlorinated Polyvinyl Chloride)
hot and cold water plumbing systems in
Southern Africa.

OVERVIEW



Flo-Tek manufactures FlowGuard™ CPVC pipes and fittings for Hot & cold water applications as per requirements of BOBS, SANS, ISO 15877 Part 2, 3 & 5 and ASTM D-2846.

Flo-Tek is a licensee of Lubrizol – USA, manufacturing and commercialising the FlowGuard™ CPVC Hot and Cold water systems for Plumbing applications in the Southern Africa region.

What is CPVC?

Chlorinated Polyvinyl Chloride (CPVC): A thermoplastic produced by chlorination of polyvinyl chloride (PVC) resin.

Thermoplastic: Polymer material that turns to liquid when heated and becomes solid when cooled.

CPVC technology was developed in the late 50s and the first plumbing installation was in the 60s in the US – most of these installations are still working successfully.

There are more than 300 million meters of CPVC piping installed around the world, to date.

Features and Benefits

- > Resistance to High temperatures (up to 95°C)
- > Corrosion Resistance
- > High Chlorine resistance in water
- > Easy & Fast Installation
- > Less prone to theft
- > Cost effective

The Right Product

Flo-Tek FlowGuard™ CPVC pipe is the right choice for today's hot and cold water distribution systems. Stringent product quality testing in independent laboratories ensures that Flo-Tek FlowGuard™ CPVC products satisfy the highest international standards, combining performance, durability, reliability, safety and cost savings.

Flo-Tek FlowGuard™ CPVC pipes and fittings are produced according to the BOBS, SANS, ISO 15877 standards; in sizes ranging from 16mm to 160mm; and pressure ratings of PN 16, PN 20, and PN 25, as well Flo-Tek manufactures according to ASTM D-2846 from ½" to 6" in SDR 11 and SDR 13.5.

The Quality Choice

Flo-Tek FlowGuard™ CPVC products are strong and tough, needing less hangers and supports and with a higher pressure bearing capability than many alternative plastic systems.

Oxygen permeation through the pipe wall and the subsequent corrosion of metal components is eliminated. Heat loss and thermal expansion are reduced.

The Result

Flo-Tek FlowGuard™ CPVC hot and cold water system means a high quality piping system with a lower installed cost, a plumbing system that will perform for the entire life of the building.

It is quieter than metal pipe systems and virtually eliminates the risk of water hammer and the possibility of condensation while providing superior heat retention.

A History of Proven Performance

The reputation of FlowGuard™ CPVC is built on over 50 years of trouble free performances. Based on the advanced polymer chemistry of Lubrizol, CPVC plumbing systems have a proven track record in millions of homes, apartments, hotels, hospitals and offices worldwide.

FEATURES AND BENEFITS

Physical Properties

Flo-Tek FlowGuard™ CPVC piping is highly durable. It can be relied upon to deliver impact strength and a heat deflection temperature that surpasses many other piping options.

	CPVC	PVC	PPR	PEX	PB	CU
Tensile strength (MPa at 23°C)	55	50	30	25	27	>300
Coefficient of Thermal expansion (x10 ⁻⁴ K ⁻¹)	0.7	0.7	1.5	1.5	1.3	0.2
Thermal Conductivity (W/MK)	0.14	0.14	0.22	0.22	0.22	>400
Limiting Oxygen Index (LOI)	60	45	18	17	18	
Oxygen permeation (at 70°C)	< 1	(not available) similar to CPVC	(not available) similar to PB/PEX	13	16	insignificant

Temperature [°C]	Working Pressure PN 16 [bar]	Working Pressure PN 20 [bar]	Working Pressure PN 25 [bar]
20	16	20	25
40	11	14	17
60	6	8	10
80	4	4	6
95	2	3	4

Health Benefits

Flo-Tek FlowGuard™ CPVC plumbing systems are approved for contact with potable water in a wide range of countries including the USA, Canada, the UK, Japan, the E.U, and the Middle-East. Flo-Tek FlowGuard™ CPVC is certified to NSF 61 for potable water service for uncompromised water quality under all water conditions.

Flo-Tek FlowGuard™ CPVC does not break down – even under the harshest of water conditions. It keeps water pure without any traces of corrosion or chemicals.

Even after years of use in the most aggressive conditions, Flo-Tek FlowGuard™ CPVC piping won't corrode, standing up to low PH water, coastal salt air exposure and corrosive soils.

CPVC: Antimicrobial Performance

Dr. Paul Sturman concludes*:

“CPVC consistently outperforms most other non-metallic piping materials with regard to its ability to resist the formation of biofilms”.

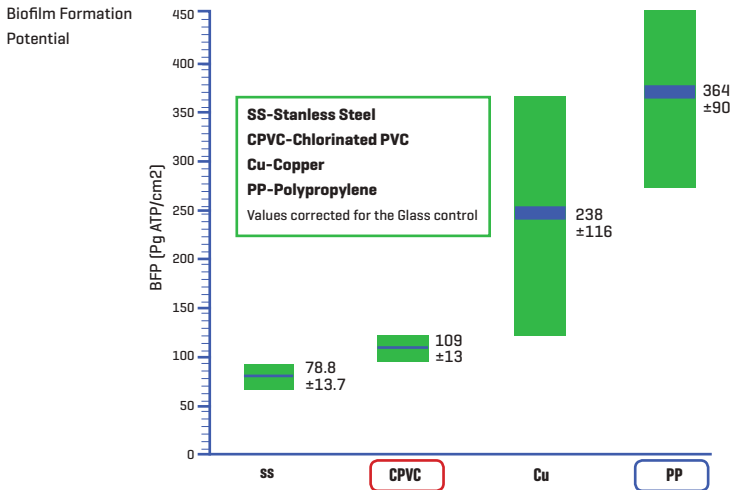

Study conducted by CRECEP in France, confirms the ability of CPVC to resist biofilm formation. Comparison of BPP (Biomass Production Potential) values observed at 30°C and 50°C.

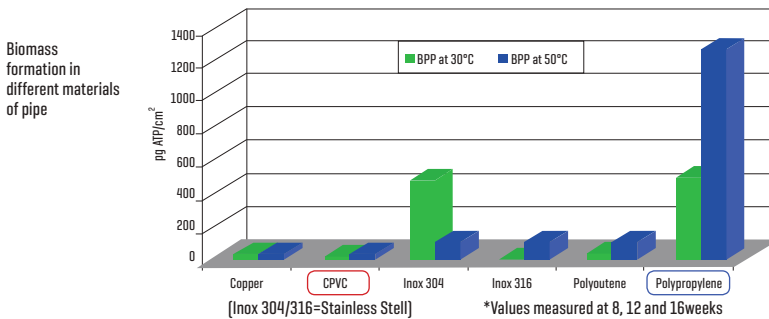

For CPVC, the growth of Legionella bacteria in the water was low.

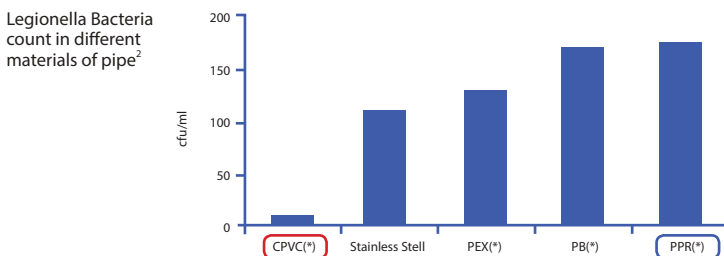

(*) Average of 2 samples

UV Resistance

FlowGuard™ CPVC resists U.V. rays.

The main degradation process caused by U.V. rays is dehydrochlorination.

In Flo-Tek FlowGuard™ CPVC this dehydrochlorination, whilst slightly accelerated by U.V., does not break down the polymer chains to any significant extent after outdoor exposure.

The effect is limited to a surface discoloration. There is a loss of impact resistance due to impact modifiers losing efficiency.

But, there is no effects on the tensile strength and modulus of elasticity of the material. The damage due to weathering is mainly a surface phenomenon.

Long Term Performance

FlowGuard™ CPVC have a track record of more than 50 years of successful performance.

Laboratory tests show that on the long run and at high temperatures FlowGuard™ CPVC outperforms PPR.

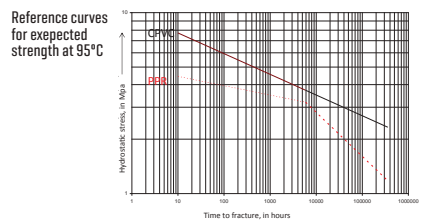

Lower Friction Loss

The smooth interior surface of the FlowGuard™ CPVC piping system assures low friction loss and higher flow rate, which results in lower pumping requirements and less energy usage.

FlowGuard™ CPVC piping system resists rusting, pitting, scaling and corrosion, so the design flow rate can be maintained for the life of the system.



INSTALLATION GUIDE



Cutting

Flo-Tek FlowGuard™ CPVC pipe can be easily cut with a wheel-type plastic tube cutter, a hack saw or other fine toothed hand or power saw.

Use of ratchet cutters is permitted, provided blades are sharpened regularly. A meter box should be used to ensure a square cut when using a saw.

Cutting pipe as squarely as possible provides an optimal bonding area within the joint. If any indication of damage or cracking is evident at the pipe end, cut off at least 5 cm beyond any visible crack.



Deburring / Bevelling

Burrs and filings can prevent proper contact between pipe and fitting during assembly, and should be removed from the outside and inside of the pipe.

A chamfering tool is preferred but a pocketknife or file are suitable for this purpose. A slight bevel on the end of the pipe will ease entry of the pipe into the fitting socket and minimize the chances of pushing solvent cement to the bottom of the joint.



Fitting Preparation

Wipe any dirt or moisture from the fitting socket and pipe end. Check the dry fit of the pipe and fitting. The pipe should make contact with the socket wall 1/3 to 2/3 of the way into the fitting socket. At this stage, pipe should not bottom out in the socket.

Tools Required



Pipe Cutter



Chamfering Tool



Flo-Tek CPVC Solvent Cement

4



Solvent Cement Application

Use only Flo-Tek FlowGuard™ CPVC approved yellow One Step cement.

Make sure the pipe and fitting surfaces are dry.

Apply a sufficient, even coat of cement on the pipe end, then apply a thin coat inside the fitting socket (make sure not to use an excessive amount of cement especially on the fitting).

Professional installation with Flo-Tek FlowGuard™ CPVC approved solvent cement is your assurance of a worry free system.

The bonding of Flo-Tek FlowGuard™ CPVC is simple, long lasting, safe and does not need expensive tools.

Note: If this bead is not continuous around the socket edge, it may indicate that insufficient cement was applied. In this case remake the joint to avoid potential leaks.

Set and Cure Times

Solvent cement set and cure times are a function of pipe size, temperature and relative humidity. Curing time is shorter for drier environments, smaller sizes and higher temperatures.

Refer to the table below for minimum cure times after the last joint has been made before pressure testing can be done.

In certain areas, quick drying one-step cements are available. These cements avoid the need for a primer.

Special care should be exercised when assembling CPVC systems in extremely low temperatures (below 4°C) or extremely high temperatures (above 38°C).

Note: Dried cement cannot be recovered and should be discarded. In extremely hot temperatures, make sure both surfaces to be joined are still wet with cement when putting them together.

5

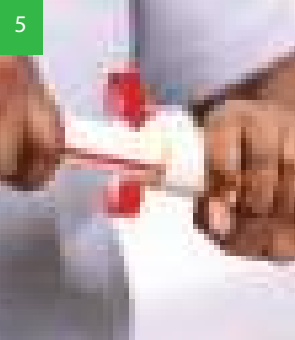



Assembly

Immediately insert the pipe into the fitting socket, rotating the pipe 1/4 to 1/2 turn while inserting. This motion ensures an even distribution of cement within the joint. Properly align the fitting.

Hold the assembly for approximately 10 seconds, allowing the joint to set-up. Wipe excess cement from the pipe and fittings surfaces for an attractive, professional appearance.

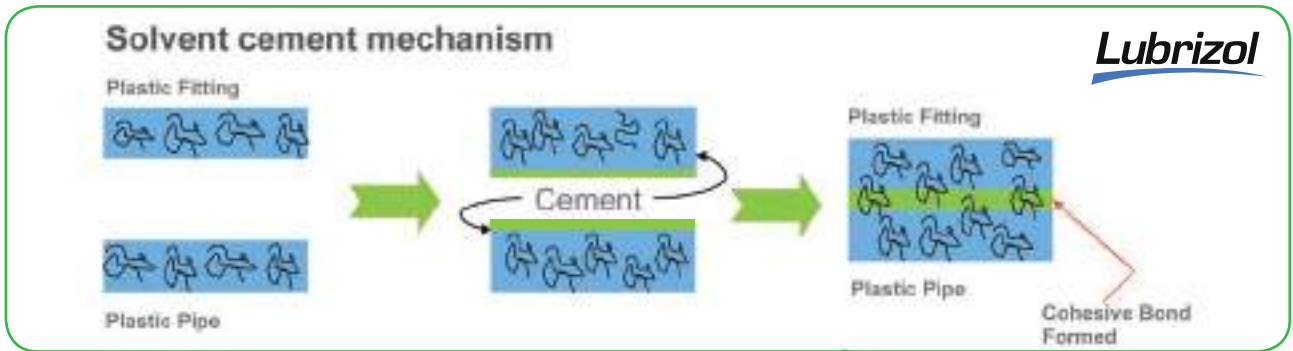
An even bead of cement should be evident around the joint.



Plastic pipe and fittings are composed of large polymer molecules (illustrated by ) . Solvent cement is made by dissolving a polymer in a liquid. When solvent cement is applied to the plastic part, the liquid penetrates the surface and softens the outer layer of the plastic part. The polymer chains then interpenetrate with one another to form a strong cohesive bond.

SET AND CURE TIMES TABLE

Ambient Temp.	Pipe Size	
	16-25mm	32-63 mm
Above 15°C	1 hour	2 hours
4°C to 15°C	2 hours	4 hours
Under 4°C	4 hours	8 hours

PRESSURE TESTS INSTRUCTIONS

All Flo-Tek FlowGuard™ CPVC installations must be pressure tested according to DIN 1988.

The procedure consists of two parts:

- Introductory test.
- Main test.

Prior to carrying out the test:

- > A visual check on all joints must be carried out prior to pressure testing.
- > Flushing of the system should occur prior and after pressure testing.
- > Pressure gauges which can measure a pressure difference of 0,1 bar must be used.
- > The pressure gauge must be fitted at the lowest point of the installation.
- > Pipes must be filled up with filtered water without any air pocket

Introductory test: 30 minutes + 30 minutes.

The introductory test involves applying a test pressure equal to 1.5 times the permissible operating pressure, but at least 10 Bar.

This pressure must be re-stored twice within the space of 30 minutes at intervals of 10 minutes.

Following a test period of a further 30 minutes, the test pressure must not have fallen by more than 0,6 bar.

The installation must remain 100% watertight: no leakage.

Main test: 120 minutes.

The main test must be conducted immediately after the introductory test.

The test takes 2 hours. At the end of this period, the test pressure recorded after the introductory test (10 Bar) must not have fallen by more than 0,2 bar.

The installation must remain 100% watertight: no leakage.

Installation Recommendations:

Do's

- > Use applicator that is approximately 1/2 of the pipe diameter

- > Check pipe ends for cleanliness
- > Let air pressure out of system after testing
- > Deburr and chamfer pipe ends after cutting
- > Have clean / straight cuts
- > Rotate pipe a 1/4 to 1/2 turn when making joints and hold in place for 5-10 seconds
- > Remove rocks or sharp objects from trench
- > Use thread sealants and firestop materials that are compatible with CPVC

Do not

- > Use dull or damaged cutters
- > Allow YELLOW solvent cement to puddle in system
- > Use solvent cement that has gelled / thickened
- > Allow CPVC to come within 15 cm (6") of radiant heat sources
- > Use pre-lubricated insulation or petroleum-based products
- > Use pipe straps or hangers with rough or sharp edges

THERMAL EXPANSION

The stresses developed in Flo-Tek FlowGuard™ CPVC are generally much smaller than those developed in plastics systems for equal temperature changes because of significant differences in elastic modulus.

Therefore, expansion loop requirements are not significantly different than those recommended for copper tubing.

Thermal expansion can generally be accommodated at changes in direction, on a long straight run, an offset or loop based on the following chart is required.

Expansion Loop Length (Cm) For (44° C) Temperature Change					
Normal pipe size	Length of run in meters				
	6	12	18	24	30
20mm	43	56	69	79	86
25mm	48	66	81	91	104
32mm	53	74	91	104	117
40mm	58	81	102	117	130
50mm	63	89	109	127	142
63mm	71	102	124	145	163

CPVC pipe expansion table

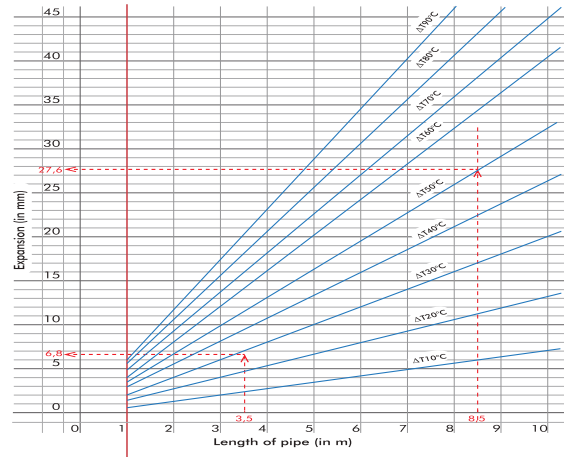

CPVC pipe expansion loop calculation

Example:
Pipe size=20mm
length of run=18m
L=69cm from table

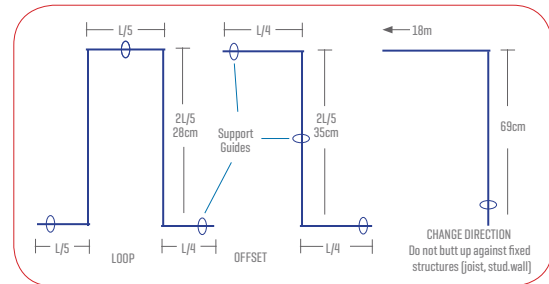

HANGERS AND SUPPORTS

Because Flo-Tek FlowGuard™ CPVC tubing is rigid, it requires fewer supports than flexible plastic systems.

The table below shows the required vertical and horizontal spacing of the hangers.

Piping should not be anchored tightly to supports, but rather secured with smooth straps or hangers that allow for movement caused by expansion and contraction.

Most hangers designed for metal pipes are suitable for Flo-Tek FlowGuard™ CPVC Hangers should not have rough or sharp edges which come in contact with the tubing.

Diameter of pipe (mm)	Hangers Spacing (mm)			Vertical
	Horizontal			
	20°C	60°C	80°C	
16	850	700	600	1000
20	950	850	750	1200
25	1050	950	850	1300
32	1200	1100	1000	1400
40	1350	1300	1150	1500
50	1500	1450	1350	1700
63	1700	1650	1550	2000



PRODUCT DATA

PIPES PN 20

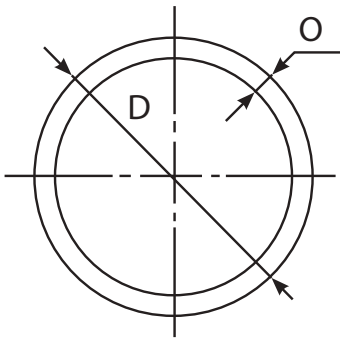

Diameter D	e/mm	PN	Reference	Unit	Weight per Meter [kg]	Internal Diameter [mm]
16	1,5	20	4520160201	ML	0,115	13,00
20	1,9	20	4520200201	ML	0,187	16,20
25	2,3	20	4520250201	ML	0,270	20,40
32	2,9	20	4520250251	ML	0,470	26,20
40	3,7	20	4520320201	ML	0,701	32,60
50	4,6	20	4520400201	ML	1,090	40,80
63	5,8	20	4520500201	ML	1,720	51,40
75	6,8	20	TUBE CPVC	ML	2,420	61,40
90	8,2	20	TUBE CPVC	ML	3,720	73,60
110	10	20	TUBE CPVC	ML	5,130	90,00

Note: All dimensions are in mm

Elbow 90°

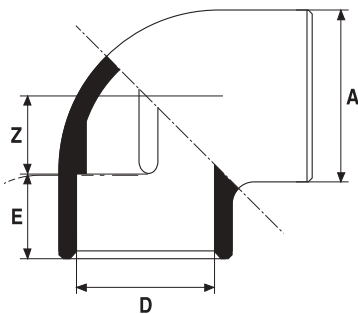

Dn	Reference	A [min]	D [avg]	Z [avg]	E [min]
16	45006016000	21,2	16,2	9,0	14,0
20	45006020000	26,6	20,2	11,0	16,0
25	45006025000	32,95	25,35	13,5	25,0
32	45006032000	40,35	32,35	17,0	30,0
40	45006040000	50,35	40,35	21,0	35,0
50	45006050000	62,95	50,35	26,0	41,0
63	45006063000	76,15	63,55	32,5	50,0
75	GIC 75	90,65	75,45	38,5	60,0
90	GIC 90	108,68	90,45	46,0	72,0
110	GIC 110	132,45	110,45	56,0	88,0

Note: All dimensions are in mm

Elbow 45°

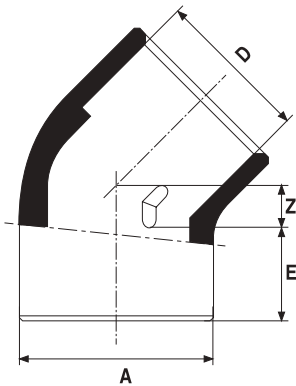

Dn	Reference	A [min]	D [avg]	Z [avg]	E [min]
16	45007016000	21,2	16,2	9,0	14,0
20	45007020000	26,6	20,2	11,0	16,0
25	45007025000	32,95	25,35	13,5	25,0
32	45007032000	40,35	32,35	17,0	30,0
40	45007040000	50,35	40,35	21,0	35,0
50	45007050000	62,95	50,35	26,0	41,0
63	45007063000	76,15	63,55	32,5	50,0
75	GIC 75	90,65	75,45	38,5	60,0
90	GIC 90	108,68	90,45	46,0	72,0
110	GIC 110	132,45	110,45	56,0	88,0

Note: All dimensions are in mm

Tee 90°

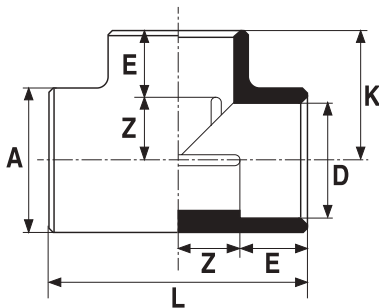

Dn	Reference	A [min]	D [avg]	Z [avg]	E [min]	K	L
16	45008016000	21,2	16,2	9,0	14,0	23,0	46,0
20	45008020000	26,6	20,2	11,0	16,0	27,0	54,0
25	45008025000	32,95	25,35	13,5	25,0	38,5	77,0
32	45008032000	40,35	32,35	17,0	30,0	47,0	94,0
40	45008040000	50,35	40,35	1,0	35,0	56,0	112,0
50	45008050000	62,95	50,35	26,0	41,0	67,0	134,0
63	45008063000	76,15	63,35	32,5	50,0	82,5	165,0
75	75 TIC	90,65	75,45	8,5	60,0	98,5	197,0
90	90 TIC	108,65	90,45	46,0	72,0	118,0	236,0
110	110 TIC	132,45	110,45	56,0	88,0	144,0	288,0

Note: All dimensions are in mm

Female Elbow Brass

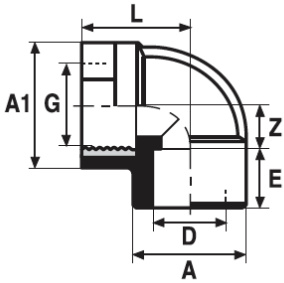

Dn	Reference	A[mm]	D[avg]	Z[avg]	E[mm]	G	A1	L
16x1/2"	45006020050	21,2	6,2	9,0	14,0	1/2"	39,8	28,5
20x1/2"	45006016050	26,75	20,35	11,0	20,0	1/2"	42,0	27,5
25x3/4"	45006025075	32,95	25,35	13,5	25,0	3/4"	43,0	33,8
32x1"	GIRC 32x1"	40,35	32,35	17,0	30,0	1"	49,3	39,7

Notes: All dimensions are in mm

Socket

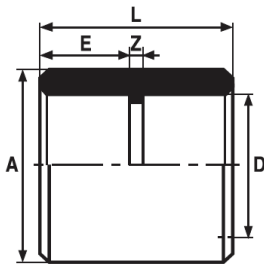

Dn	Reference	A[mm]	D[avg]	Z[avg]	E[mm]	L
16	45001016000	21,2	16,2	3,0	14,0	31,0
20	45001020000	26,6	20,2	3,0	16,0	35,0
25	45001025000	32,95	25,35	3,0	25,0	53,0
32	45001032000	40,35	32,35	3,0	30,0	63,0
40	45001040000	50,35	40,35	3,0	35,0	73,0
50	45001050000	62,95	50,35	3,0	41,0	85,0
63	45001063000	76,15	63,35	3,0	50,0	103,0
75	MIC 75	90,65	75,45	4,0	60,0	124,0
90	MIC 90	108,65	90,45	5,0	72,0	149,0
110	MIC 110	132,45	110,45	6,0	88,0	182,0

Notes: All dimensions are in mm



Reducer Sleeve

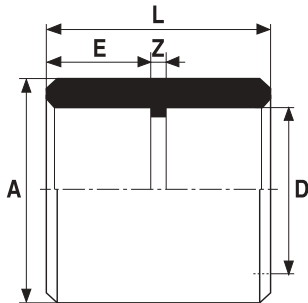

Dn	Reference	D[min]	D[avg]	Z[avg]	E[min]	L[min]
20/16	45003020016	20,0	16,35	4,0	16,0	20,0
25/20	45003025016	25,0	20,35	5,0	20,0	25,0
32/20	45003025020	32,0	20,35	10,0	20,0	30,0
32/25	45003032020	32,0	25,35	5,0	25,0	30,0
40/20	45003032025	40,0	20,35	15,0	20,0	35,0
40/25	45003040020	40,0	25,35	10,0	25,0	35,0
40/32	45003040025	40,0	32,35	5,0	30,0	35,0
50/20	45003040032	50,0	20,35	15,0	20,0	35,0
50/25	45003050020	50,0	25,35	16,0	25,0	41,0
50/32	45003050025	50,0	32,35	11,0	30,0	41,0
50/40	45003050032	50,0	40,35	6,0	35,0	41,0
63/32	45003050040	63,0	32,35	20,0	30,0	50,0
63/40	45003063032	63,0	40,35	15,0	35,0	50,0
63/50	45003063040	63,0	50,35	9,0	41,0	50,0
75/50	DIC 75/50	50,35	50,35	19,0	41,0	60,0
75/63	DIC 75/63	75,0	63,35	10,0	50,0	60,0
90/75	DIC 90/75	90,0	75,45	12,0	60,0	72,0
110/90	DIC 110/90	110,0	90,45	16,0	72,0	88,0

Note: All dimensions are in mm

End Cap

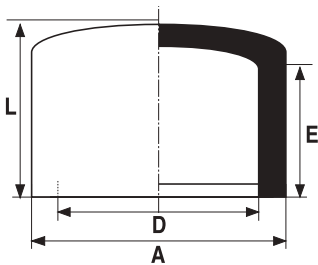

Dn	Reference	A [min]	D [Avg]	E[min]	L [min]
16	45012016000	21,2	16,2	14,0	19,5
20	45012020000	26,6	20,2	16,0	22,2
25	45012025000	32,8	25,2	18,5	25,3
32	45012032000	40,35	32,35	30,0	37,0
40	45012040000	50,35	40,35	35,0	43,0
50	45012050000	62,95	50,35	41,0	50,3
63	45012063000	79,15	63,35	50,0	60,9
75	CIC 75	93,85	75,45	60,0	73,2
90	CIC 90	112,65	90,45	72,0	88,1
110	CIC 110	137,45	110,45	88,0	107,5

Note: All dimensions are in mm

Tee Female Brass

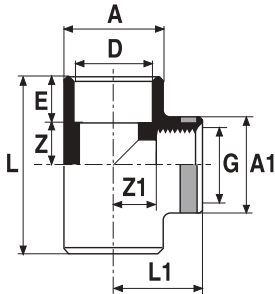

Dn	Reference	A[min]	D[avg]	Z[avg]	E[min]	L	G	A1	Z1	L1
16x1/2"	45011016050	21,1	16,2	9,0	14,0	46,0	1/2"	39,5	15,0	30,0
20x1/2"	45011020050	26,75	20,35	11,0	20,0	62,0	1/2"	42,5	13,5	30,0
25x3/4"	45011025075	32,95	25,35	13,5	25,0	77,0	3/4"	43,0	16,5	34,5
32x1"	TIRC 32x1"	40,35	32,35	17,10	30,0	94,0	1"	49,2	20,5	40,5

Note: All dimensions are in mm

Straight Brass Male Adaptor

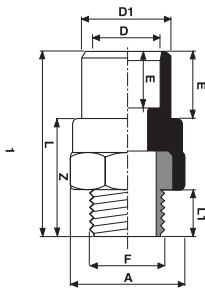

Dn	Reference	D1[min]	D[avg]	A	E1	E	F	L1	L	Z
16x1/2"	45030016050	21,2	16,2	39,5	14,0	16,0	1/2"	12,0	46,7	30,5
20x1/2"	45030020050	26,75	20,35	34,9	20,0	19,0	1/2"	12,0	48,0	29,5
25x3/4"	45030025075	31,75	25,35	40,8	25,0	15,6	3/4"	13,7	59,5	43,0
32x1"	45030032100	40,35	32,35	47,5	30,0	17,0	1"	16,6	65,0	47,5
40x1 1/4"	45030040125	48,55	40,35	59,5	35,0	19,5	1 1/2"	22,0	75,5	56,0
50x1 1/2"	45030050150	60,35	50,35	69,0	41,0	26,5	1 1/2"	20,0	81,0	54,5
63x2"	45030063200	76,15	63,35	81,0	50,0	33,7	2"	26,5	98,5	64,0

Note: All dimensions are in mm

Wall Plate Female Brass

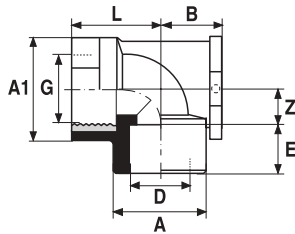

Dn	Reference	A[min]	D[avg]	Z[avg]	E[min]	G	A1	L	B
20x1/2"	45007020050	26,75	20,35	11,0	20,0	1/2"	42,0	27,0	12,5
25x3/4"	45007025075	32,95	25,35	13,35	25,0	1/8"	46,5	34,0	17,5

Straight Brass Female Adaptor

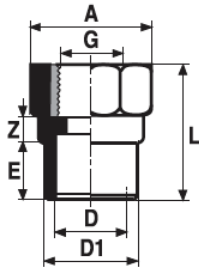

Dn	Reference	D1[min]	D[avg]	A	E[min]	G	Z	L
16x1/2"	45032016050	21,2	16,2	39,5	14,0	1/2"	3,0	34,5
20x1/2"	45032020075	26,75	20,35	39,5	20,0	1/2"	3,0	35,2
25x3/4"	45032025100	32,95	25,35	45,5	25,0	3/4"	3,0	48,0
32x1"	45032032100	40,35	32,35	50,5	30,0	1"	3,0	48,5
40x1 1/4"	45032040125	48,55	40,35	60,0	35,0	1 1/4"	3,0	54,5
50x1 1/2"	45032050150	60,35	50,35	69,0	41,0	1 1/2"	3,0	61,0
63x2"	45032063200	76,15	63,35	81,0	50,0	2"	3,0	72,0

Note: All dimensions are in mm

Bracket for Pipe

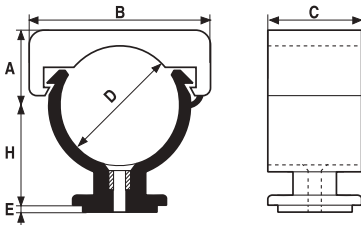

Dn	Reference	D	A	B	C	E	H
20	45021016000	20,5	10,0	31,5	16,0	1,9	18,0
25	45021020000	25,5	11,0 3	8,0	16,0	1,9	21,0
32	45021025000	32,8	15,0	48,0	18,0	2,7	5,5

Note: All dimensions are in mm

Cross over



Dn	Reference	d[avg]	D[min]	L[min]	H[min]	A	d1	d2
20	45019016000	20.2	28.0	16.0	160.0	26,5	14,0	21,8
25	45019020000	25.2	34.8	18.5	180.0	29,5	17,7	26,7
32	45019025000	32.2	42.0	22.0	220.0	32,5	22,2	32,0

Note: All dimensions are in mm

One Step Solvent Cement

Sizes	Reference
59ml	45012010118
118ml	45012010237
237ml	45012010473
473ml	45012010059
946ml	45012010946

Note: All dimensions are in mm



CPVC COMPARED TO COPPER

Today's builders and contractors use Flo-Tek FlowGuard™ CPVC systems, that offer significant advantages over copper.

CPVC	COPPER
Corrosion Resistance	
<ul style="list-style-type: none"> ● Immune to Corrosion regardless of water quality. 	<ul style="list-style-type: none"> ● Corrodes and develops pin holes and pitting. ● Needs water quality control to perform well.
Ease of Installation + Economy	
<ul style="list-style-type: none"> ● Proven highly reliable solvent cement welding. ● No heat, no flame. ● Simple tools ● Fast easy installation, less labour ● Lower cost material ● Stable prices. ● Reduces installation cost by 50% and more. 	<ul style="list-style-type: none"> ● Requires highly skilled workers. ● Time consuming, labour intensive installation. ● Use of torches, fire hazard. ● Skyrocketing cost in the past years + fluctuating prices. ● Labour intensive installation. ● Installed cost can be double that of FlowGuard™ CPVC.
Quiet Operation	
<ul style="list-style-type: none"> ● Independent lab tests show that FlowGuard™ CPVC can be 4 times quieter than copper. Virtually noise free. No banging pipes. 	<ul style="list-style-type: none"> ● Copper pipes can be noisy and prone to water hammer.
Superior Hydraulics	
<ul style="list-style-type: none"> ● FlowGuard™ CPVC never scales, provides full unimpeded flow over the life of the building. 	<ul style="list-style-type: none"> ● Copper scales overtime, restricts water flow. It will eventually need to be replaced.
Insulating Properties	
<ul style="list-style-type: none"> ● Superior insulation properties reduce condensation and minimise need for insulation. ● More energy efficient system. 	<ul style="list-style-type: none"> ● Needs extensive insulation to prevent heat loss in heating pipes. ● May require insulation for cold water pipe to prevent condensation.
Greater Material Safety-Human Health	
<ul style="list-style-type: none"> ● No copper contamination. FlowGuard™ CPVC will never leach any harmful metals or chemicals. It meets NSF Std 61 for use with drinking water. ● Superior antibacterial performance 	<ul style="list-style-type: none"> ● Copper corrosion contaminates drinking water and causes health problems. ● Biofilm formation potential is much higher than FlowGuard™ CPVC.
Sustainability	
<ul style="list-style-type: none"> ● FlowGuard™ CPVC uses significantly less energy to manufacture. It contributes much less than other piping materials to global warming. ● FlowGuard™ CPVC has a smoother internal surface, which requires less pumping power and thus less energy to operate. 	<ul style="list-style-type: none"> ● Copper requires more energy to manufacture, install, operate and recycle and contributes more to the global warming.
Unmatched Reliability	
<ul style="list-style-type: none"> ● FlowGuard™ CPVC piping systems have a track record of more than 50 years of reliable performance. 	<ul style="list-style-type: none"> ● Copper piping system have an average life span of 20 years, and many copper systems start to fail in less than 2 years due to pitting, scaling or corrosion.

CPVC COMPARED TO PPR

Don't be confused by the many different types of materials when you can choose the safe and durable Flo-Tek FlowGuard™ CPVC technology.

CPVC	PPR
Durability	
<ul style="list-style-type: none"> 60% greater tensile strength Nearly twice the flexural strength of polypropylene. 	<ul style="list-style-type: none"> Used for drainage applications when the pipe exceeds 75°C. Can only meet ASTM F2389 pressure rating of 6.8bar at 82°C and only recommended for reinforcement and a thicker pipe wall, reducing the flow area.
Proven Performance	
<ul style="list-style-type: none"> Proven track record of more than 50 years of successful performance in the U.S. NSF International certifies all FlowGuard™ piping systems, for potable water. 	<ul style="list-style-type: none"> Does not have a certification from the Plastic Pipe Institute®, (PPI), validating a 50-year life expectancy using Hydrostatic Design Basis (HDB) in a chlorinated water system. Not included in the Uniform Plumbing Code™. Some forms of polypropylene piping have not achieved NSF 61 certification for potable water systems
Chlorine Resistance	
<ul style="list-style-type: none"> Ideal for chlorinated hot and cold water systems. Recommended by the American Water Works Association and the Environmental Protection Agency for concentrated chlorine piping in drinking water treatment systems. 	<ul style="list-style-type: none"> Erodes in hot chlorinated water systems causing pieces of material to flake off, which can clog fixtures and appliances Eroded polypropylene pipe continually loses its ability to hold pressure over time When tested in accordance with the NSF P171 Protocol for Chlorine Resistance of Plastic Piping Materials, hot chlorinated water at 5 ppm can degrade polypropylene by up to 50% after only 10 months of exposure at a low flow rate.
Superior Installation	
<ul style="list-style-type: none"> More than twice the impact strength of unreinforced polypropylene, resulting in far fewer problems when cutting pipe on the job. Solvent cement welding process means fast and easy assembling. Chemically welded joints are the strongest part of the system. Since no heat is required during installation, there is no fire risk. 	<ul style="list-style-type: none"> Fusion welding tool heats up to 260°C., which creates a burn hazard and adds time to the installation process. Labour intensive and difficult to install in tight spaces. Heat fusion leads to bead formation internally and externally. <ul style="list-style-type: none"> Prone to bacteria growth. Increase frictional loss. Reduces flow rate. Increases mineral deposits that further reduce flow.

Environmental Impact

- More recyclable than polypropylene containing fiberglass / Aluminum.
- Widely used in designs qualifying for points in common sustainability rating systems.
- Listed by U.S. National Institute of Standards and Technology in BEEs 4.0 database.
- Cannot meet the strength and performance requirements of many applications without fiberglass reinforcement
- More expensive and not recyclable due to its fiberglass layer
- Environmental claims are not independently supported by the . National Institute of Standards and Technology.

Greater Material Safety – Human Health

- Multiple international studies have confirmed the superior antimicrobial performance of CPVC over other piping materials, especially polypropylene.
- Biofilm forms when biomass such as bacteria, fungi, algae and mold adhere to surfaces in wet environments.
- A study conducted by a leading water research institute in 2007 showed that polypropylene had the greatest potential to form biofilms of all the piping materials studied.

Greater Material Safety – Fire

- In the event of a fire, will not sustain a flame and is not combustible
- Testing confirms that smoke from burning CPVC is considered no more toxic than traditional building materials, such as wood
- Combustible, increase fire damage.
- Requires the use of an expensive insulating wrap before the pipe can be installed in a plenum.
 - ▶ Interferes with the ability to perform a heat-fusion weld.
 - ▶ Must be partially removed at every point.
 - ▶ Creates a condition whereby portions of the piping system can be left exposed and susceptible to fire.



FLO-TEK FLOWGUARD™ CPVC GLOBAL STANDARDS, CODES AND APPROVALS STANDARDS

- BOBS SANS EN ISO 15877, Plastics piping systems for hot and cold water installations - Chlorinated poly (Vinyl chloride) (PVC-C) Part 2, 3 and 5
- ASTM D-2846, Specification for Chlorinated Poly (Vinyl Chloride) (CPVC) Plastic Hot- and Cold-Water Distribution Systems
- ASTM D1784, Specification for Rigid Poly (Vinyl Chloride) Compounds and Chlorinated Poly (Vinyl Chloride) (CPVC) Compounds
- ASTM F437, Standard Specification for Threaded Chlorinated Poly (Vinyl Chloride) (CPVC) Plastic Pipe Fittings,
- Schedule 80
- ASTM F439, Standard Specification for Chlorinated Poly (Vinyl Chloride) (CPVC) Plastic Pipe Fittings, Schedule 80
- ASTM F441, Standard Specification for Chlorinated Poly (Vinyl Chloride) (CPVC) Plastic Pipe, Schedules 40 & 80
- ASTM F2855, Standard for CPVC/Al/CPVC
- AFNOR PVC-C Piping systems for hot and cold water installations
- BS 7291 / 4 Thermoplastics pipes and associated fittings for hot and cold water for domestic purposes and heating installations in buildings
- DIN-8079 Chlorinated polyvinyl chloride (PVC-C) pipes - Dimensions
- DIN-8080 Chlorinated polyvinyl chloride (PVC-C) pipes - General quality requirements, testing.

PERFORMANCE STANDARDS & APPROVALS

- ASTM F493, Standard Specification for Solvent Cements for Chlorinated Poly (Vinyl Chloride) (CPVC) Plastic Pipe and Fittings
- ASTM F656, Standard Specification for Primers for Use in Solvent Cement Joints in Poly (Vinyl Chloride) (PVC)
- Plastic Pipe and Fittings
- NSF SE 8459 CPVC Schedule 40 & 80 Pipe and Fitting with High HDB at 180° F
- NSF Standard 14, Plastic Piping Components and Related Materials.
- NSF Standard 61, Drinking Water System Components – Health Effects

INSTALLATION STANDARDS

- ASTM D2855, Standard Practice for Making Solvent Cemented Joints and Poly (Vinyl Chloride) (PVC) Pipe and
- Fittings
- ASTM F402, Standard Practice for Safe Handling of Solvent Cements, Primers, and Cleaners Used for Joining
- Thermoplastic Pipe and Fittings

FREQUENTLY ASKED QUESTIONS

1 – What is CPVC?

A: Chlorinated polyvinyl chloride (CPVC), is a thermoplastic produced by chlorination of polyvinyl chloride (PVC) resin, used for hot and cold water Piping systems.

CPVC is the first choice of material for potable water supply across the world and is in use for more than 50 years.

2 – How to join CPVC Pipes and Fittings

A: Easy as 1, 2 & 3 CUT, GLUE & JOIN

3 – For how long CPVC has been installed worldwide?

A: For over 50 years with more than 300.000.000 meters of pipes installed worldwide. But in Southern Africa is a new piping system for Hot & Cold water Plumbing applications.

4 - Is Flo-Tek FlowGuard™ CPVC pipe & fittings suitable for Hot & Cold water applications?

A: Yes, The Flo-Tek FlowGuard™ CPVC Piping System is manufactured as per BOBS SANS EN ISO 15877 for an expected 50 years life span when used for hot water temperature of 70°C @ 6 Bars of constant pressure, and short time exposure to 95°C @ 6 Bars in case of a geyser or boiler failure.

5 – What are the pipe and fittings sizes available?

A: Pipes and fittings are available as follow:

ISO 15877 – Metric OD Sizes – 16, 20, 25, 32, 40, 50 & 63mm

Flo-Tek FlowGuard™ CPVC piping is also available on request from 75 to 110mm OD for Commercial projects.

6 – What is the PN rating for Flo-Tek FlowGuard™ CPVC pipes and fittings?

A: PN 20 for pipes and PN 25 for fittings.

7 – Can I use PVC solvent cement to join Flo-Tek FlowGuard™ CPVC pipes and fittings?

A: NO, only use the Flo-Tek FlowGuard™ Yellow One Step Solvent cement specially designed to join CPVC pipes and fittings.

Note: The use of a non- Approved solvent cement will make the system fail the joints and the guarantee will be null and void.

8 – Do we require to apply a primer before using the yellow CPVC solvent cement?

A: NO, because the Flo-Tek FlowGuard™ CPVC yellow solvent cement is a ONE STEP cement.

9 – After installation using Flo-Tek yellow CPVC solvent cement, how long do I need to wait to open the water?

A: 60 minutes at 15°C temperature and above for 16, 20 & 25mm Pipes. (check table in page 11)

10 – Can I install Flo-Tek FlowGuard™ CPVC pipes outdoor, exposed directly to the sun?

A: Yes, The main degradation process is dehydrochlorination, not oxidation. This dehydrochlorination, whilst slightly accelerated by U.V., does not break down the polymer chains to any significant extent after outdoor exposure, being mainly limited to a surface discoloration effect.

However for extra protection, Flo-Tek recommends to protect all pipes and fittings installed outdoors to prevent

any kind of mechanical damages to the system.

11 – Can I connect CPVC directly to the Geyser?

A: It is recommended to follow SANS 10254 guidance for Geysers installations.

12 – How to do a transition from CPVC to Copper?

A: Using a special transition coupling as CPVC and Copper have different OD, for example Copper is 15mm OD and Flo-Tek CPVC is 16mm OD.

13 – How is CPVC expansion in hot water, compared to other plastic piping systems?

A: It's better due to a lower thermal expansion coefficient, when compared to PP-R and PE-X piping systems.

14 - What are the main advantages for a plumber to select Flo-Tek FlowGuard™ CPVC Piping system?

- Fast and Easy installation on site, no need for expensive tools or electricity to run fusion welding machine, just a wheel pipe cutter and the correct yellow Flo-Tek FlowGuard™ CPVC solvent cement.
- Cost effective, CPVC has proven to be a cost effective piping system when compared to copper.
- No theft on site, CPVC as a plastic piping system reduces the theft of piping systems on site
- High Chlorine resistance in hot water, when compared to metallic piping like Copper or G.I., as well compared to PP-R and PEX piping systems, CPVC is unaffected by the chlorine present in potable water supply.

THE LUBRIZOL ADVANTAGE

Through product innovation, technical expertise and the many value-added services it offers customers, Lubrizol continues to advance CPVC solutions for the building and construction market. From design of the base materials, to the production of resins and compounds, Lubrizol has established world-class research and development capabilities, differentiating it from its competitors and setting a higher standard for product quality.



FlowGuard™ PIPE & FITTINGS

Lubrizol is a leading provider of base materials for residential and commercial piping with the most widely used CPVC plumbing system in the world. FlowGuard™ piping systems offer a unique combination of benefits, including corrosion resistance, a fast and easy installation process, quiet operation and superior energy efficiency. Beyond residential settings, FlowGuard™ piping can work seamlessly with larger Corzan® Piping Systems in certain commercial projects requiring larger diameter pipes, such as high-rise hotels, universities, hospitals and retail applications.



BLAZEMASTER® FIRE SPRINKLER SYSTEMS

Specially engineered BlazeMaster® CPVC pipe and fittings meet and exceed global performance and manufacturing standards for residential and commercial fire sprinkler systems, making it the most specified non-metallic option for fire suppression systems in the world. In addition to the corrosion-resistant properties inherent in all Lubrizol CPVC piping, BlazeMaster systems are specially engineered for exceptional flame and smoke resistance, high impact and temperature resistance, and larger internal diameter to allow for increased flow rates and hydraulic capabilities.



CORZAN® INDUSTRIAL SYSTEMS

Corzan® and Corzan® HP Industrial Systems meet the critical demands of industrial environments, using specially engineered CPVC polymer technology from Lubrizol. Corzan Industrial Systems are designed for use in demanding applications such as chemical processing, industrial manufacturing, marine usage, water treatment and more. All Corzan systems are highly corrosion resistant, have decreased installation costs and handle the effects of extreme outdoor ambient conditions. Corzan HP piping also has three times the drop-impact strength of standard CPVC, a 25 percent higher pressure rating than standard CPVC and the highest heat deflection temperature (HDT) of any CPVC piping compound. With a dedication to meeting and exceeding industry standards, Lubrizol's Corzan HP compounds are the first and only Schedule 40/80 piping system made from fully pressure-rated materials.

CHEMICAL RESISTANCE TABLES

Chemical Name	Temperature		Chemical Name	Temperature		Chemical Name	Temperature		Chemical Name	Temperature	
	73°F 23°C	Max Temp°C		73°F 23°C	Max Temp°C		73°F 23°C	Max Temp°C		73°F 23°C	Max Temp°C
Acetaldehyde	N	N	Ammonium Carbonate	R	93	Cellosolve all types	N	N	Corn Syrup	R	93
Acetic Acid, up to 10%	R	82	Ammonium Chloride	R	93	Chloric Acid	R	82	Cottonseed Oil	N	N
Acetic Acid, greater than 10%	C	C	Ammonium Citrate	R	93	Chlorinated Solvents	N	N	Creosote	N	N
Acetic Acid Glacial	N	N	Ammonium Dichromate	R	93	Chlorinated water, (Hypochlorite)	-	-	Cresol	N	N
Acetic Anhydride	N	N	Ammonium Fluoride	R	93	Chlorine, Dry gas	A	A	Crotonaldehyde	N	N
Acetone, up to 5%	R	82	Ammonium Hydroxide, 28%	N	N	Chlorine liquid	N	N	Cumene	N	N
Acetone, greater than 5%	C	C	Ammonium Hydroxide, 10%	N	N	Chlorine trace in air	R	93	Gupric Fluoride	R	93
Acetone, pure	N	N	Ammonium Hydroxide, 3%	C	N	Chlorine wet gas	A	A	Gupric Sulfate	R	93
Acetyl Nitrile	N	N	Ammonium Nitrate	R	93	Chlorine dioxide, aqueous, sat'd	-	-	Cuprous Chloride	R	93
Acrylic Acid	N	N	Ammonium Persulfate	R	-	Chlorine water Sat'd	R	93	Cyclohexane	N	N
Acrylonitrile	N	N	Ammonium Phosphate	R	C	Chlorobenzene	N	N	Cyclohexanol	N	N
Adipic Acid, sat'd in water	R	93	Ammonium Sulfamate	R	93	Chlorofonn	N	N	Cyclohexanone	N	N
Alcohols	C	C	Ammonium Sulfate	R	93	Chromic Acid 40%	R	82	Detergents	C	C
Allyl Alcohol	C	C	Ammonium Sulfide	R	93	Chromic nitrate	R	93	Dextrin	R	93
Allyl Chloride	N	N	Ammonium Thiocyanate	R	93	Citric Acid	R	93	Dextrose	R	93
Alum, All varieties	R	93	Ammonium Tartrate	R	93	Citrus oils	N	N	Dibutyl Phthalate	N	N
Aluminum Acetate	R	93	Amyl Acetate	N	N	Coconut Oil	N	N	Dibutyl Ethyl Phthalate	N	N
Aluminum Chloride	R	93	Amyl Alcohol	C	C	Copper Acetate	R	93	Dichlorobenzene	N	N
Aluminum Fluoride	R	93	Ami Chlorid	N	N	Copper Carbonate	R	93	Dichloroethylene	N	N
Aluminum Hydroxide	R	93	Aniline	N	N	Copper Chloride	R	93	Diethylamine	N	N
Aluminum Nitrate	R	93	Antimony Trichloride	R	93	Copper Cyanide	R	93	Diethyl Ether	N	N
Aluminum Sulfate	R	93	Aqua Regia	R	N	Copper fluoride	R	93	Dill Oil	N	N
Amines	N	N	Aromatic Hydrocarbons	N	N	Copper Nitrate	R	93	Dimethylformamide	N	N
Ammonia	N	N	Arsenic Add	R	-	Copper Sulfate	R	93	Disodium Phosphate	R	93
Ammonium Acetate	R	93	Barium Carbonate	R	93	Corn Oil	N	N	Distilled water	R	93
Ammonium Benzoate	R	93	Barium Chloride	R	93				EDTA, Tetrasodium	R	93
Ammonium Bifluoride	R	93	Barium Hydroxide	R	93				Esters	N	N

R: Resistance

N: Non Resistance

C: Check with supplier

A: Additional information required

Chemical Name	Temperature		Chemical Name	Temperature	
	73°F 23°C	Max Temp°C		73°F 23°C	Max Temp°C
Barium Nitrate	R	93	Butyric Acid pure	N	N
Barium Sulfate	R	93	Cadmium Acetate	R	93
Barium Sulfide	R	93	Cadmium Chloride	R	93
Beer	R	93	Cadmium Sulfate	R	93
Beet sugar liquors	R	93	Calcium Acetate	R	93
Senzaldehyde	N	N	Calcium Bisulfide	R	93
Benzene	N	N	Calcium Bisulfite	R	93
Benzoic acid Sat'd in water	R	N	Calcium Carbonate	R	93
Benzyl Alcohol	N	N	Calcium Chlorate	R	93
Benzyl Chloride	N	N	Calcium Chloride	R	93
Bismuth carbonate	R	93	Calcium Hydroxide	R	93
Black Liquor	R	93	Calcium Hypochlorite	R	93
Bleach,household (5%CL)	R	93	Calcium Nitrate	R	93
Bleach,household (15% CL)	R	93	Calcium Oxide	R	93
Borax	R	93	Calcium Sulfate	R	93
Boric Acid	R	93	Cane Sugar liquors	R	93
Brine Acid	R	93	Caprolactam	N	N
Bromine	N	N	Caprolactone	N	N
Bromine, acqueous, sat'd	R	93	Carbilol	N	N
Bromobenzene	N	N	Carbon Dioxide	R	93
Bromotoluene	N	N	Carbon Disulfide	N	N
Butanol	C	C	Carbon Monoxide	R	93
Butyl Acetate	N	N	Carbon Tetrachloride	N	N
Butyl Carbitol	N	N	Carbonic Acid	R	93
Butyl Cellosolve	N	N	Castor Oil	N	N
Butyric Acid, up to 1%	R	R	Caustic Potash	A	A
Butyric Acid greater than 1%	C	C	Caustic Soda	A	A

Chemical Name	Temperature		Chemical Name	Temperature	
	73°F 23°C	Max Temp°C		73°F 23°C	Max Temp°C
Ethanol , up to 5%	R	82	Glycol Ethers	N	N
Ethanol, greater than 5%	C	C	Green Liquor	R	93
Ethers	N	N	Halocarbon Oils	N	N
Ethyl Acetate	N	N	Heptane	C	-
Ethyl Acrylate	N	N	Hydrazine	N	N
Ethyl Benzene	N	N	Hydrocholric Acid	R	82
Ethyl Chloride	N	N	Hydrochloric Acid,36%	R	82
Ethylene Bromide	N	N	Hydrofluoric Acid, 3%	R	-
Ethylene Chloride	N	N	Hydrofluoric Acid, 48%	C	C
Ethylene Dia ine	N	N	Hydrofluosilicic Acid, 30%	R	82
Ethlene Glycol,up to 50%	N	N	Hydrogen Peroxid, 50%	R	-
Ethylene Glycol greater 50%	R	82	Hydrogen Sutfide, Acqueous	R	82
Ethylene Oxide	C	C	Hypochlorous Acid	C	C
Ferric Chloride	N	N	Isopropanol	C	C
Ferric Hydroxide	R	93	Ketones	N	N
Ferric	R	93	Kraft Liquors	R	93
Ferric sulfate	R	93	Lactic Acid, 25%	R	93
Fluorine Gas	R	93	Lactic Acid, 85% (Full strength)	R	C
Fluosilicic Acid, 30%	N	N	Lead Acetate	R	93
Formaldehyde	N	82	Lead Chloride	R	93
Formic Acid up to 25%	R	N	Lead Nitrate	R	93
Formic Acid greater than 25%	C	82	Lead Sulfate	R	93
Freons	C	N	LemonOil	N	N
Fructose	R	C	Limonene	N	N
Gasoline	N	93	Linseed Oil	N	N
Glucose	R	N	Lithium Chloride	R	93
Glycerine	R	93	Lithium Sulfate	R	93

R: Resistance

N: Non Resistance

C: Check with supplier

A: Additional information required

Chemical Name	Temperature		Chemical Name	Temperature	
	73°F 23°C	Max Temp°C		73°F 23°C	Max Temp°C
Lubricating Oil,ASTM1,2,3	R	-	Methyl Methacrylate	N	N
Magnesium Carbonate	R	93	Methylamine	N	N
Magnesium Chloride	R	93	Methylene chloride	N	-
Magnesium Citrate	R	93	Mineral Oil	R	N
Magnesium Fluoride	R	93	Monoethanolamine	N	N
Magnesium Hydroxide	R	93	Motor Oil	N	82
Magnesium Salts, inorganic	R	93	Muriatic Acid	R	N
Magnesium	R	93	Naphthatene	N	93
Nitrate	R	93	Nickel Acetate	R	93
Magnesium Oxide	R	93	Nickel Chloride	R	93
Magnesium Sulfate	R	93	Nickel Nitrate	R	93
Maleic Acid, 50%	R	82	Nickel Sulfate	R	66
Manganese Sulfate	R	93	Nitric Acid, up to 25%	R	54
Mercuric Chloride	R	93	Nitric Acid,25%-35%	R	41
Mercuric Cyanide	R	93	Nitric Acid,70%	R	N
Mercuric Sulfate	R	93	Nitrobenzene	N	N
Mercurous Nitrate	R	93	1-Octanol	C	N
Mercury	R	82	Oils, edible	N	N
Methane Sufonic Acid	R	82	Oils,Sour Crude	N	N
Methanol, up to10%	R	C	Oleum	N	N
Methanol, greater than10%	C	N	Olive Oil	N	N
Methanol, pure	N	N	Oxalic Acid sat 'd	R	77
Methyl Cellosolve	N	N	Oxygen	R	82
Methyl Chloride	N	N	Ozonized water	R	93
Methyl Ethyl Ketone	N	N	Palm Oil	N	N
Methyl Formate	N	N	Paraffin	R	82
Methyl Isobutyl Ketone	N	N	Peanul Oil	N	N

Chemical Name	Temperature		Chemical Name	Temperature	
	73°F 23°C	Max Temp°C		73°F 23°C	Max Temp°C
Silver Nitrate	R	93	Sodium Iodide	R	93
Silver Sulfate	R	93	Sodium Metaphosphate	R	93
Soaps	R	93	Sodium itrate	R	93
Sodium Acetate	R	93	Sodium Nitrite	R	93
Sodium Aluminate	R	93	Sodium Perborate	R	82
Sodium Arsenate	R	93	Sodium Perchlorate	R	82
Sodium Benzoate	R	93	Sodium Phosphate	R	93
Sodium Bicarbonate	R	93	Sodium Sifcate	R	93
Sodium Bichromate	R	93	Sodium Sulfate	R	93
Sodium Bisulfate	R	93	Sodium Sulfide	R	93
Sodium Bisulfite	R	93	Sodium Sulfite	R	93
Sodium Borate	R	93	Sodium Thiosulfate	R	93
Sodium Bromide	R	93	Sodium Tripolyphosphate	R	93
Sodium Carbonate	R	93	Soybean Oil	N	N
Sodium Chl-orate	R	93	Stannic Chloride	R	93
Sodium Chloride	R	93	Stannous Chloride	R	93
Sodium Chlorite	R	93	Stannous Sulfate	R	93
Sodium Chromate	R	93	Starch	R	93
Sodium Cyanide	R	93	Stearic Acid	R	-
Sodium Dichromate	R	93	Strontium Chloride	R	93
Sodium Ferricyanide	R	93	Styrene	N	N
Sodium Ferrocyanide	R	93	Sugar	R	93
Sodium Fluoride	R	93	Sulfamic Acid	R	82
Sodium Formate	R	93	Sulfur	R	-
Sodium Hydroxide	A	A	Sulfuric Acid, Fuming	N	N
Sodium Hypobromite	R	93	Sulfuric Acid,98%	R	52
Sodium Hypochlorite	R	93	Sulfuric Acid,85%	R	77

R: Resistance

N: Non Resistance

C: Check with supplier

A: Additional information required

Chemical Name	Temperature		Chemical Name	Temperature	
	73°F 23°C	Max Temp°C		73°F 23°C	Max Temp°C
Perchloric Acid,1006	R	-	Potassium Hypochlorite	R	93
Phenylhydrazine	N	N	Potassium Iodide	R	93
Phosphoric Acid	R	82	Potassium Nitrate	R	93
Phosphorous tridlloride	N	N	Potassium Perborate	R	82
Picric Acid	N	N	Potassium Perdlilorate, sat'd	R	82
Pine Oil	N	N	Potassium Permanganate, sat'd	R	82
Plating solutions	N	82	Potassium persulfate, sat'd	R	-
Polyethylene Glycol	R	N	Potassium phosphate	R	93
Potash	N	93	Potassium Sulfate	R	93
Potassium Acetate	R	93	Potassium Sulfide	R	93
Potassium Bicarbonate	R	93	Potassium Sulfite	R	93
Potassium Bichromate	R	93	Potassium tripolyphosphate	R	93
Potassium Bisulfate	R	93	Propanol, up to 0,5%	R	82
Potassium Borate	R	93	Propanol,greater than 0,5%	C	C
Potassium Bromate	R	93	Propionic Acid, uto 2%	R	82
Potassium Bromide	R	93	Propionic Acid, greater than2%	C	C
Potassium Carbonate	R	93	Propionic Acid pure	N	N
Potassium Chlorate	R	93	Propylene Dichloride	N	N
Potassium Chlorrde	R	93	Propytene Glycol, up to 25%	R	82
Potassium Chromate	R	93	Propylene Glycol,greater 25%	C	C
Potassium Cyanate	R	93	Propylene Oxide	N	N
Potassium Cyanide	R	93	Pyridine	N	N
Potassium Dichromate	R	93	Sea water	R	93
Potassium ferricyanide	R	93	Silicic Acid	R	-
Potassium Hydroxide	R	93	Silicon Oxide	R	-
Potassium Fluoride	R	93	Silver Chloride	R	93
					93

Chemical Name	Temperature		Reagent	Temperature	
	73°F 23°C	Max Temp°C		73°F 23°C	Max Temp°C
Sulfuric Acid,80%	R	82	Xylene	N	N
Sulfuric Acid,50%	R	82	Zinc Acetate	R	93
Tall Oil	C	C	Zinc Carbonate	R	93
Tannk Acid,30%	R	-	Zinc Ch Ioride	R	93
Tartaric Acid	R	-	Zinc Nitrate	R	93
Terpenes	N	N	Zinc Sulfate	R	93
Tetrahydrofuran	N	N			
Tetrasodium pyrophosphate	R	93			
Texanol	N	N			
Thionyl chloride	N	N			
Toluene	N	N			
Tributyt Phosphate	N	N			
Trichloroethylene	N	N			
Trisodium Phosphate	R	93			
Turpentine	N	N			
Urea	R	82			
Urine	R	93			
Vegetable Oils	N	N			
Vinegar	R	93			
Vinyl Acetate	N	N			
Water, Deionized	R	93			
Water, Demineralized	R	93			
Water Distilled	R	93			
Water, Salt	R	93			
Water, swimming Pool	R	93			
WD-40	C	C			
White Liquor	R	93			

R: Resistance

N: Non Resistance

C: Check with supplier

A: Additional information required

WORLDWIDE PROJECT REFERENCES

Sofitel Rabat, Morocco



Cheikh Khalifa Casablanca Hospital, Morocco



Hotel Tour Hassan Rabat, Morocco



Skygate, Lebanon



Chu Marrakech, Morocco



Golf Al Maaden Marrakech, Morocco



Dakhla Airport, Morocco



Charles De Gaulle Airport, France.



Golden Temple, Amristar, India.



Printania Hotel, Lebanon



Beijing Olympics 2008, China.



Hotel Intercontinental De Paris, France.



Burj Khalifa



CCTV China.





OUR NETWORK

Botswana | South Africa | Angola | Namibia | Zambia

Botswana

Tel: +267 533 2180 | Fax: +267 533 3146

South Africa

Tel: +27 11 316 6891 | Fax: +27 11 316 6896

Angola

Tel: +244 2222 90662 | Fax: +244 2222 90880

Namibia

Tel: +264 61 244239 | Fax: +264 61 232339

Zambia

Tel: +260 211 244673



www.flotekafrika.com